

PROFESSIONAL REFERENCE GUIDE updated 21dec07

INDEX

Pg.	contents
1.	Index
2.	How thermostats work
3.	Thermostat general wiring chart
4.	Heat pump operation
5.	2 Wire Heat, Gas millivolt system wiring
6.	2 Wire Heat, 24VAC wiring
7.	3 Wire Heat, and Fan wiring
8.	4 Wire Heat, Fan, and Cool
9.	5 Wire Heat, Fan and Cool (two power wires)
10.	5 Wire 2 heat, fan, and cool
11.	4 Wire Heat Pump (without auxiliary heat)
12.	5 Wire Heat Pump (with auxiliary heat)
13.	Zoned Forced Air Heating and Cooling 6 wire (main) 3 wire (remotes)
14.	Zoned hot water systems 3 wire
15.	RV, Swamp coolers, Mobile Home systems
16.	Line Voltage thermostats (single pole and double pole)
17.	Line voltage cooling and Controlling humidity
18.	Humidifying
19.	De-humidifying using the A/C or using an external de-humidifier
20.	De-humidifying (using an External humidistat)
21.	Thermostat Power (and remote power)
22.	Fan control: Manual, heating, cooling
23.	General Information: swing, anticipator, accuracy, calibrate room temp
24.	General Info continued: Compressor delay, differential, reset
25.	Trouble shooting: fan, heat, compressor, 24VAC, Short cycle
26.	Test long cycling, fan not running, random resets, B wire info.
27.	Safety

THERMOSTATS FOR HVAC (heat, ventilation, air conditioning)

A thermostat is an electronic switch much like a light switch, i.e., the switch is either ON (contacts closed) or OFF (contacts open). In a thermostat this is done several ways.

1. The old mercury thermostats use a vial of mercury. When the vial is tipped one way, the mercury closes two contacts at that end by touching them both. When the vial is tipped the other way, it opens those two contacts. The vial of mercury is connected to a bi metal spring that reacts to temperature tipping the vial back and forth. The use of mercury is no longer acceptable, but there are many still in use. Dispose of mercury very carefully as it is extremely dangerous. Call your local recycler to find a disposal station.
2. Some mechanical thermostats use a bi metal device that causes the two contacts to touch or open depending on temperature.
3. Modern electronic thermostats use what is called a magnetic latching relay. This is a device that has two contacts that close when a coil on the relay is pulsed with a voltage. To open it, a second coil is pulsed and the contacts open. The voltage pulses are generated by the electronics inside the thermostat. The electronics is what makes thermostats different from each other. The purpose of most thermostats is to close two contacts to turn on an HVAC function and to open them to turn off that function.

There are 3 main power sources used for switching HVAC functions on and off, Gas Millivolt (750mv), 24VAC and line voltages of 115VAC or 230VAC.

1. The Gas millivolt system requires the thermostats to switch only about 750Mv (3/4 volt) to turn on and off the gas heat. Any 24VAC thermostat can be used.
2. The 24VAC systems require the thermostat to switch 24VAC. All low voltage thermostats will easily switch these two systems on and off. This is the most popular. These cannot be used for line voltage heating or cooling.
3. The 115VAC or 230VAC is used for electric baseboard, wall heaters, or ceiling heat; this takes a special "LINE VOLTAGE" Thermostat.

If the old thermostat has 2 or 4 large, stiff wires, coming out of a plastic or metal box in the wall (J box), it is likely the system is 115/230VAC, and must use a line voltage thermostat. Connecting line voltage to a 24VAC thermostat is dangerous and will severely damage the thermostat. Always shut off power before replacing any thermostat.

Standards for identifying low voltage thermostat wiring are set by the National Electrical Manufacturers Association (NEMA) Standards Publication DC 3-2003. These standards set down what letters to be used for what function in thermostats. Though many thermostats adhere to those standards, some thermostats do not. Below is a wiring chart to help compare wiring letters in most systems. As we discuss various HVAC systems, we will be using the NEMA standard letters for our thermostats. Refer to this chart when replacing old thermostats that do not have the same letters as the Ritetemp thermostats. There is no standard for wire colors.

VERY IMPORTANT NOTICE!!

BEFORE REMOVING WIRES FROM THE OLD THERMOSTAT, LOOK AT THE LETTERS NEXT TO EACH WIRE AND MARK THE WIRES WITH THE SUPPLIED LETTERS. USE THE CHART BELOW TO CROSS REFERENCE. ANY WIRES THAT WERE NOT CONNECTED TO THE OLD THERMOSTAT OR NOT USED ON THE NEW THERMOSTAT SHOULD BE TAPED OFF AND PUSHED BACK INTO THE WALL.

THERE IS NO COLOR CODE FOR THERMOSTAT WIRES
THOUGH THE COLOR OF THE WIRE MAY MATCH THE LETTER OF THE WIRE, THE COLORS THEMSELVES SHOULD NOT BE CONSIDERED.

<u>OLD THERMOSTAT</u>	<u>NEW THERMOSTAT (NEMA standard)</u>	<u>DESCRIPTION</u>
<u>WIREING FOR NORMAL HEATING AND COOLING (gas/oil/elect) (no heat pump)</u>		
R, or RH, or 4, or V	RC/RH (connected)	Single power wire
W or H	W	Heat return
W2 or H2	W2	2 nd stage of heat
W3	W3	3 rd stage of heat
Y or M	Y	Cool return (compressor)
Y2	Y2	2 nd stage of cool
Y3	Y3	3 rd stage of cool
G or F	G	Fan return
C or X	C	24VAC thermostat power

FOR SEPARATE HEAT AND COOL POWER, REMOVE THE RH/RC JUMPER AND WIRE AS SHOWN BELOW:

RH and R	RH to RH and R to RC	RH = Pwr heat and R= Pwr cool
4 and R	4 to RH and R to RC	4 = Pwr heat and R = pwr cool
RH and RC	RH to RH and RC to RC	RH = Pwr heat and RC = Pwr cool

WIRING FOR HEAT PUMP

R	RH/RC (connected)	Power
Y	Y and W	Compressor (used for heat and cool)
W2	W2	Heat pump Aux heat
E	W2	Emergency heat
O	O	Changeover (Powered in COOL)
or	or	Do not connect both O and B!
B	B	Changeover (Powered in HEAT)

Florida Heat Pump (4 wire aqua) may use W as changeover (connects to terminal O)

On a heat pump, if O and B are both present, connect O wire to O terminal and B wire to C terminal (TRANE HEAT PUMP PRODUCTS). Do not connect B wire to B terminal as it may damage the 24VAC power system.

ZONED HOT WATER MOTOR VALVES

5 or R	RH	Power wire
4 or W or NO	W	Turn Valve on
6 or Y or NC	A	Turn Valve off

ZONED HOT WATER SOLENOID VALVES

R	RH	power
Y or B or N/O	W	Turn Valve off
W or N/C	A	Turn Valve on

Heat Pump Operation

To better understand heat pumps, go to a drawing at: www.dhclimatecontrol.com/hp.htm

Heat pumps are a unique method of heating. Essentially it is a reversible air conditioner. An A/C pumps heat out of the house into an **outside air exchanger** and into the outside air. A heat pump uses very similar equipment and pumps heat from the outside air into the inside air exchanger and into the house. The heat pump has a “reversing valve” to go from COOL to HEAT. An AIR CONDITIONER gets less efficient in cooling a house as the outside air gets hotter. Similarly, the HEAT PUMP gets less efficient as the outside air gets colder.

AUXILIARY HEAT (for heat pumps)

In moderate to cold climates, the heat pump cannot keep the house warm if the outside air gets too cold. Most air exchange heat pumps have an additional heat source called AUXILIARY heat and is often electric heat strips but can be GAS or OIL. This auxiliary heat comes on to help bring the house temperature up quicker and/or provide heat when the heat pump can no longer keep up (outside temp. below 30F). Most heat pump thermostats have an EMER (emergency) or AUX ONLY switch or button to allow the auxiliary heat to be the only source of heat if the heat pump quits or can not keep up.

Some heat pumps do not need auxiliary heat if they are used in warm climates and/or if instead of using air heat exchangers, they can use ground or water (wells) heat exchanging. Ground and well temperatures stay very constant (typically 60F) so make excellent heat exchanger medium for pulling out heat (for heating a house), or dumping in heat (for cooling a house).

Some heat pumps may be 3 stages; 1 stage of compression and 2 stages of aux heat, or 2 stages of compression and 1 stage of aux heat.

The following drawings will help explain how the thermostats relay control and operate the HVAC systems.

GAS MILLIVOLT HEAT ONLY 2 WIRE

Below is a typical Gas Millivolt system. When the thermostat's relay (switch) connects RH to W, the heat comes on. If the heating system already has a thermostat connected, use the same two wires that were on the old thermostat. When there are just two wires, there is no polarity, i.e., either wire can go to RH or W.

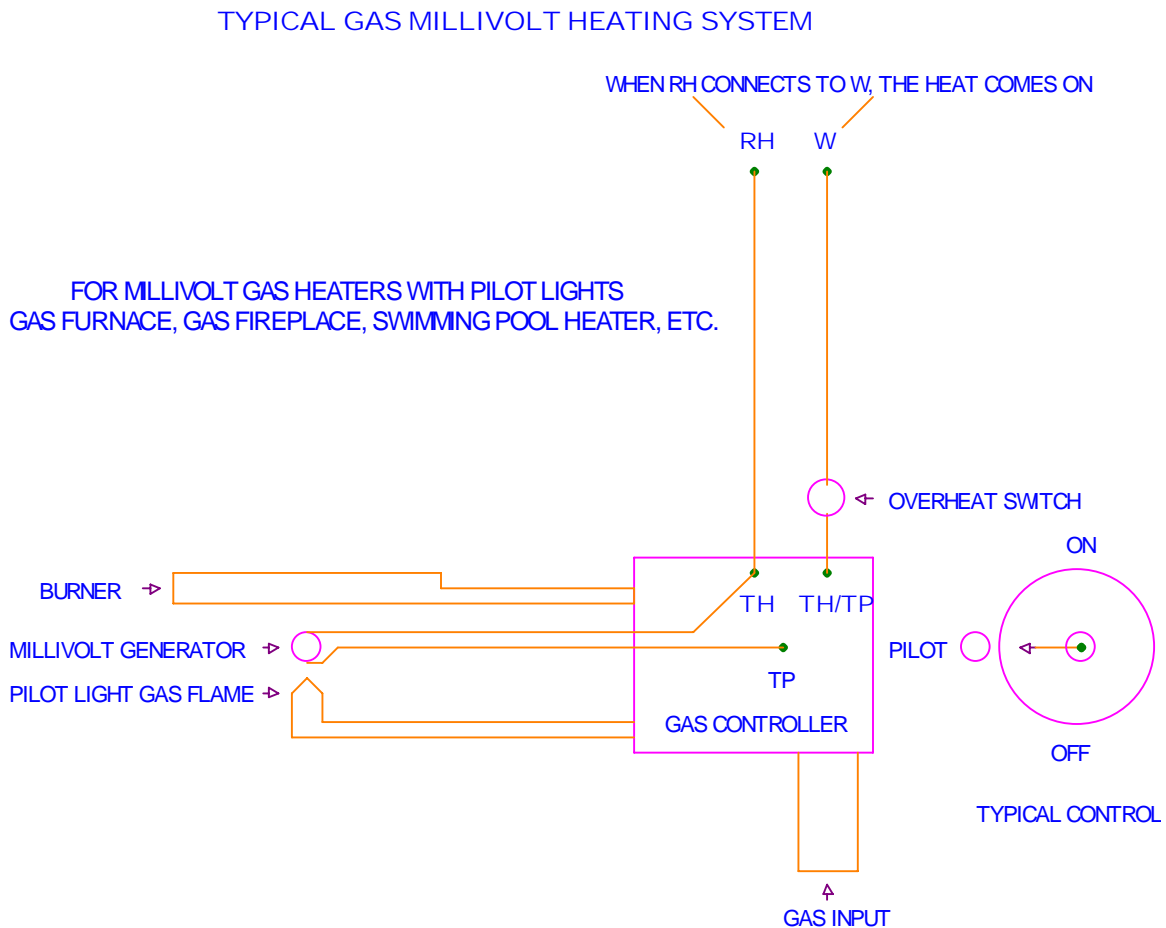

LOW VOLTAGE 24VAC HEAT ONLY 2 WIRE

The drawing below is a typical heating system using 24VAC. The heating system has a transformer that generates 24VAC to operate the furnace low voltage thermostat controlled system. The 24VAC is not an electrical hazard. It can use much smaller wire than line voltage systems, and does not need an electrical box in the wall.

When terminals RH and W are connected together by the thermostats relay (switch), the 24VAC (RH) connects to the furnace relay (W) and the heat comes on. When the relay opens the contacts, the heat goes off. This relay is operated by the thermostats computer which follows your programming commands. Some heating systems immediately come on. Some take a few seconds. With just two wires, the heating systems fan is controlled by the furnace, not by the thermostat. With only two wires, there is no polarity, ie, either wire can go to RH or W.

If a C wire is available at the thermostat, it can be used to run the thermostat in place of batteries or in addition to batteries for memory back up with longer battery life. The "C" wire is always available in a 24VAC system as it is the side of the 24VAC heat transformer that goes to all the HVAC relays. Most HVAC techs can find this point and run a wire to the thermostat if there is not one. Do not touch RH and C together.

TYPICAL 24VAC, 2 WIRE HEATING ONLY SYSTEMS

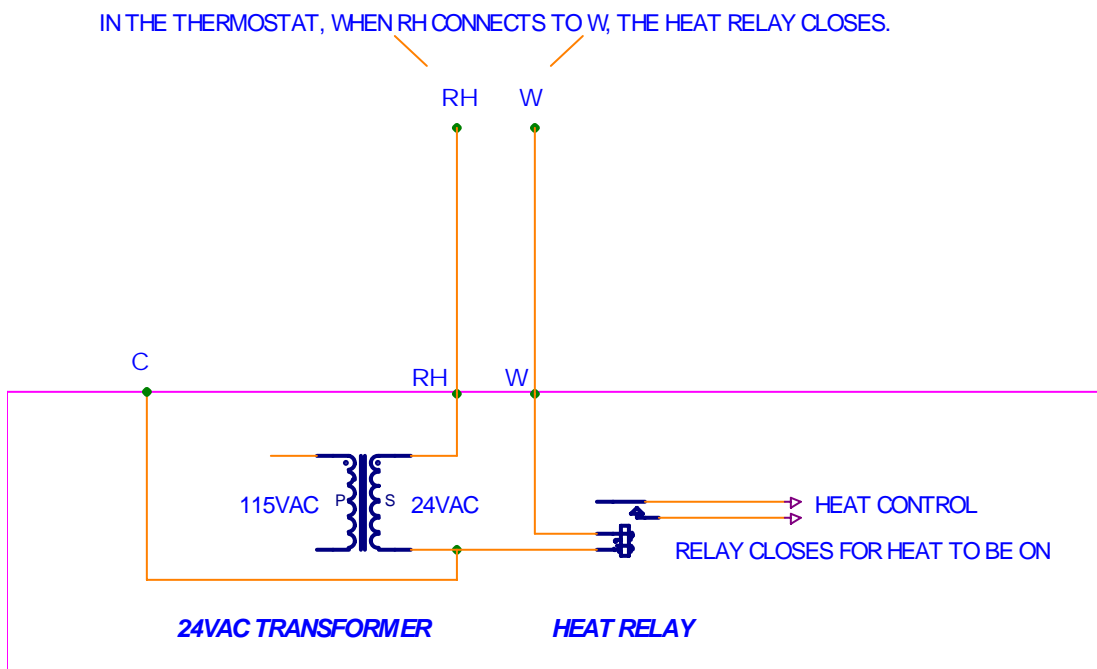

FOR ANY TWO WIRE, 24VAC HEATING SYSTEM
GAS, OIL, ELECTRIC, HOT WATER

24VAC HEAT AND FAN 3 WIRE

The drawing below is a 24VAC, three wire heat control system controlling both HEAT and FAN. The 24VAC provides power to the HEAT CONTROL relay and the FAN CONTROL relay through the thermostat.

Most gas or oil heating systems control the fan so the air is not circulated until the air is heated in the furnace and then left on after the heat is shut off to purge the heat out of the system; they do not need the thermostat to control the fan.

The G wire allows the thermostat to control the fan when the fan switch is in the ON position and/or when the GAS/ELEC jumper is in ELEC. Most electric furnaces do not have a fan control and must have the thermostat turn on the fan whenever the electric furnace is turned on. This is necessary to circulate the warmed air into the house and keeps the electric elements from overheating. Some thermostats also leave the fan running for 1 minute after the heat is shut off to purge the heat out of the system.

TYPICAL 24VAC, 3 WIRE HEATING ONLY SYSTEMS

CONNECTING RC TO G = FAN

CONNECTING RH TO W = HEAT

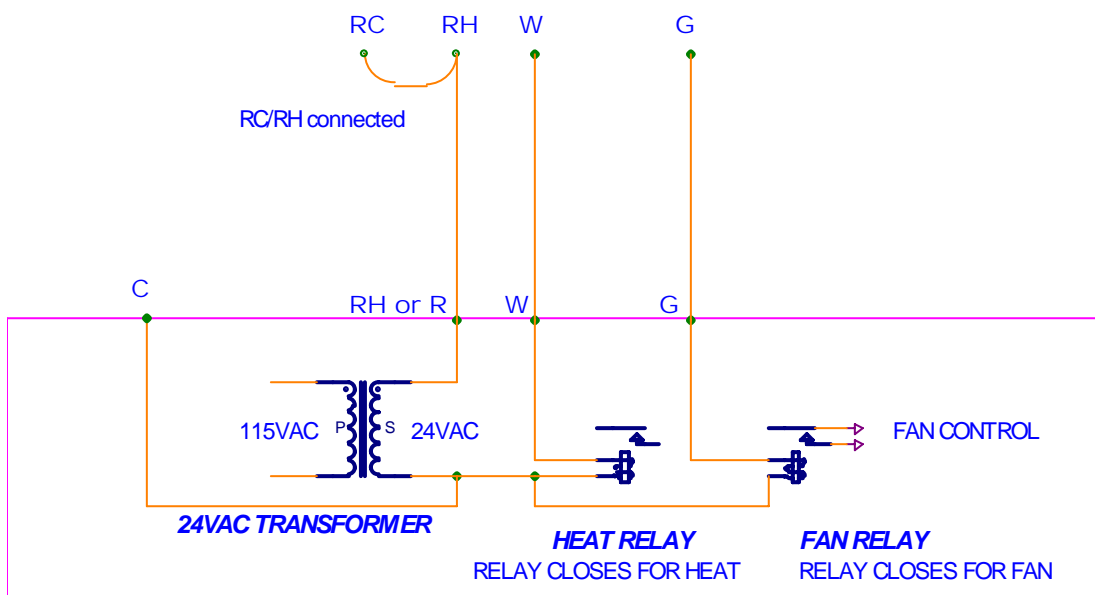

FOR THREE WIRE, FORCED AIR 24VAC HEATING SYSTEM
GAS, OIL, ELECTRIC

24VAC HEAT, FAN, AND COOL 4 WIRE

The drawing below is a standard 24VAC, 4 wire heating and cooling control system. (Not a heat pump). With the thermostats mode switch in the HEAT position, the heating functions are the same as in the 3 wire heating system.

When the thermostats mode switch is in the COOL position, the thermostat turns on the air conditioner's compressor and the air handler circulating fan at the same time.

Note the RC (power cool) and RH (power heat) terminals are connected together. This is because in a 4 wire heating and cooling system, there is a single 24VAC power transformer for both the heat and cool.

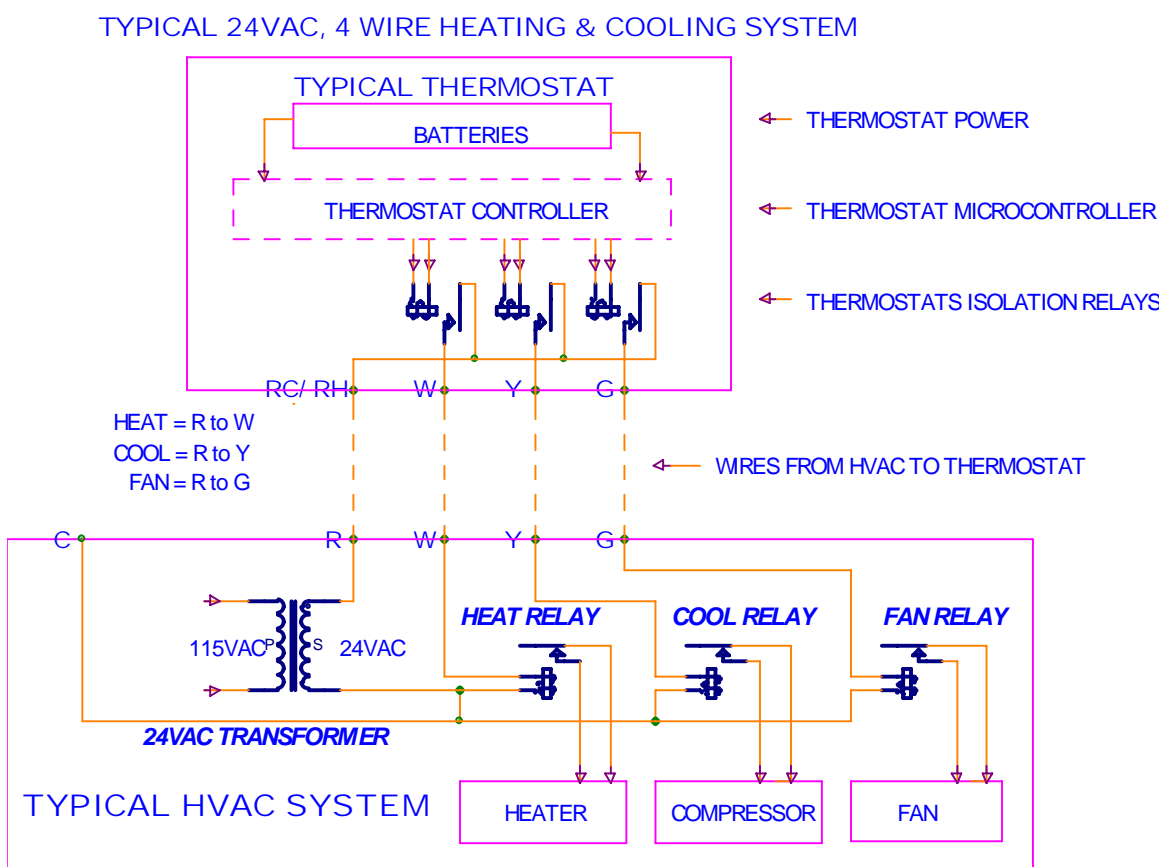

24VAC HEAT, FAN and COOL 5 wires (with separate heat & cool power)

The drawing below is a standard 24VAC, 5 wire heat and cool controls system. Some times, the heating and cooling systems have their own separate 24VAC power so there are two power sources, RC (cool and fan) and RH (heat).

The 24VAC HEAT transformer provides power to just the HEAT relay. The 24VAC COOL transformer provides power to the FAN relay and the COOL (compressor) relay.

When there are two power sources, the strap between RC and RH must be removed or damage may occur! The RC wire and the RH wire must never touch each other. It is important for the customer to turn off his power before he disconnects the old thermostat!

The 5 wire heating and cooling functions are the same as the 3 and 4 wire drawings. Note when there are two transformers, the C wire comes from the HEAT transformer.

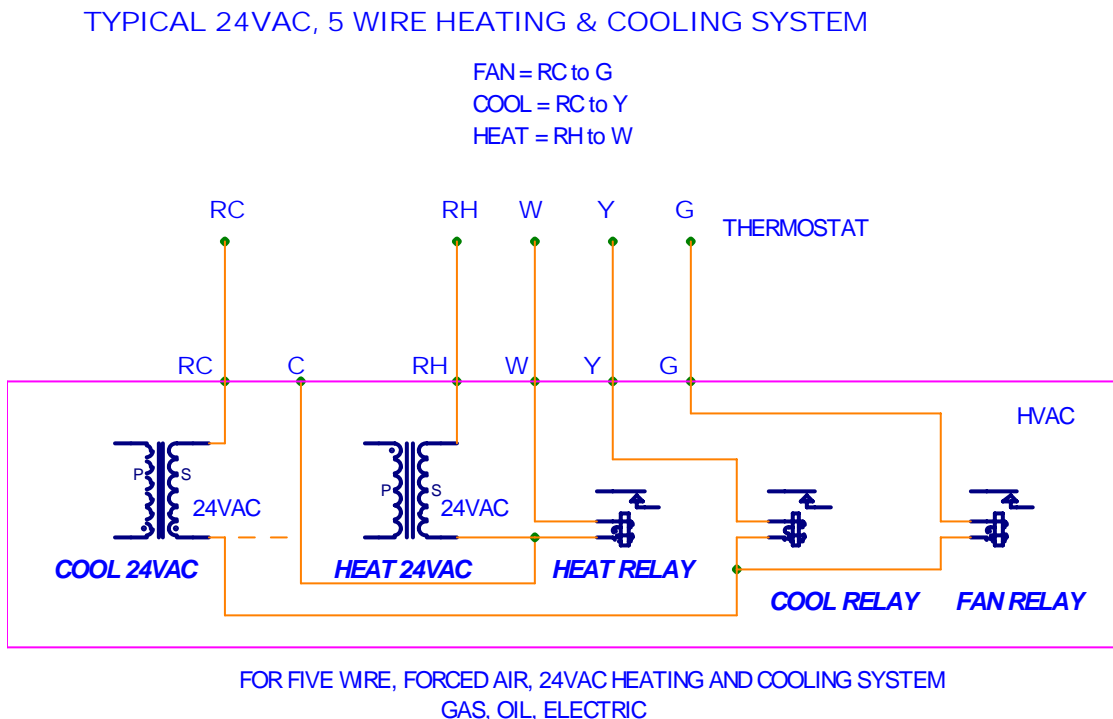

24VAC TWO STAGE HEAT AND SINGLE STAGE OF COOL 5 WIRES

The drawing below is the wiring of a typical two stage heating system and not a heat pump. From a setback of over 2F, when heat is requested by our thermostat, the first stage comes on and after 1 minute the thermostat turns on the 2nd stage of heat which also increases the fan speed. Both stages stay on all the way to target and then both stages shut off. This allows much faster recovery from a set back. After that the 1st stage generally can maintain the room temperature which is more efficient and quieter.

However if the room temperature drops below the “differential” (typically -2F) below the room temperature because the first stage cannot keep up, then the 2nd stage again comes on with the 1st stage and both run all the way to target. Also, if the customer wants to increase the room temperature faster, when he turns the target up over 2F above the room temperature, he gets more heat faster as the 2nd stage comes on all the way to the new target.

Some other thermostats do not turn on the 2nd stage for 15 minutes after the 1st stage comes on which slows down recovery.

FIVE WIRE, FORCED AIR, 24VAC, 2 STAGE OF HEATING AND SINGLE STAGE OF COOLING

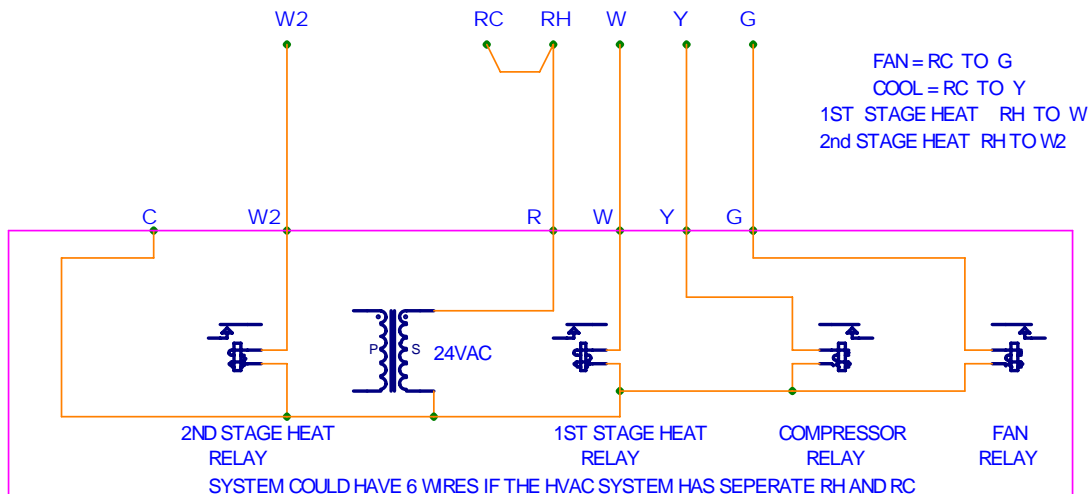

24VAC HEAT PUMP WITHOUT AUXILIARY HEAT 4 WIRE

The drawing below is a heat pump without auxiliary heat. This is useful with an air heat exchanger (outside unit) in mild climates like Florida and parts of Arizona. If the heat exchanger is in the ground or in a well (hydro), it is very efficient and auxiliary heat is not necessary.

Notice the thermostats W (heat) and Y (cool) are connected together. This is because the compressor is used when the thermostat calls for heating (W) or cooling (Y). The terminals O or B control the changeover relay which determines if it will be heating or cooling.

Heat pumps do not control the fan; thermostats used for heat pumps must have the GAS/ELECT jumper in the ELECT position.

In a heat pump, never connect both O and B or damage may result. See wiring pg 3.

NOTE: Some heat pumps use other letters for the changeover. Florida Heat Pump Co. uses the letter W on the old thermostat instead of O. (Connect their W to the stats O)

For more information about heat pumps go to: www.dhclimatecontrol.com/hp.htm

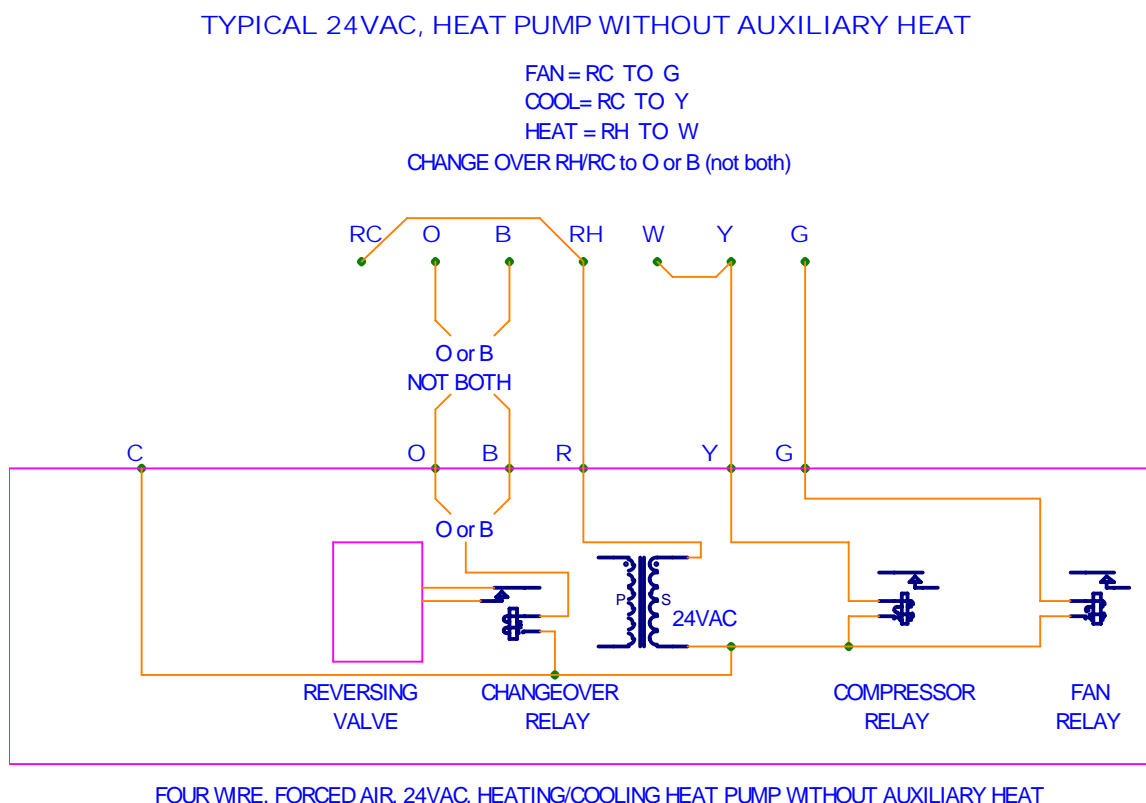

24VAC HEAT PUMP WITH AUXILIARY HEAT 5 WIRE

The drawing below is a heat pump with auxiliary heat. The auxiliary heat is usually electric heat strips mounted on the air output of the heat pump. This type of system is typically used where there is no natural gas available in cool to cold climates.

From a set back of over -2F our thermostats turn on the heat pump and after 1 minute turn on the aux electric heat. Both stay on all the way to target for fast recovery and then both shut off. The heat pump will then attempt to maintain the target room temperature. If the heat pump cannot keep up because the outside temperature is too cold, when the room temperature drops below -2F, the electric aux heat comes on with the heat pump all the way again to target. If the heat pump quits, the aux electric heat will still keep the room temperature within 2F of room temperature.

However, the auxiliary heat can also be used by itself if the heat pump quits or just can't keep up. When the thermostat is switched to AUX HEAT ONLY the heat pump is shut off and only the AUX heat is used and will maintain the target temperature.

Heat pumps do not control the fan; thermostats used for heat pumps must have the GAS/ELECT jumper in the ELECT position.

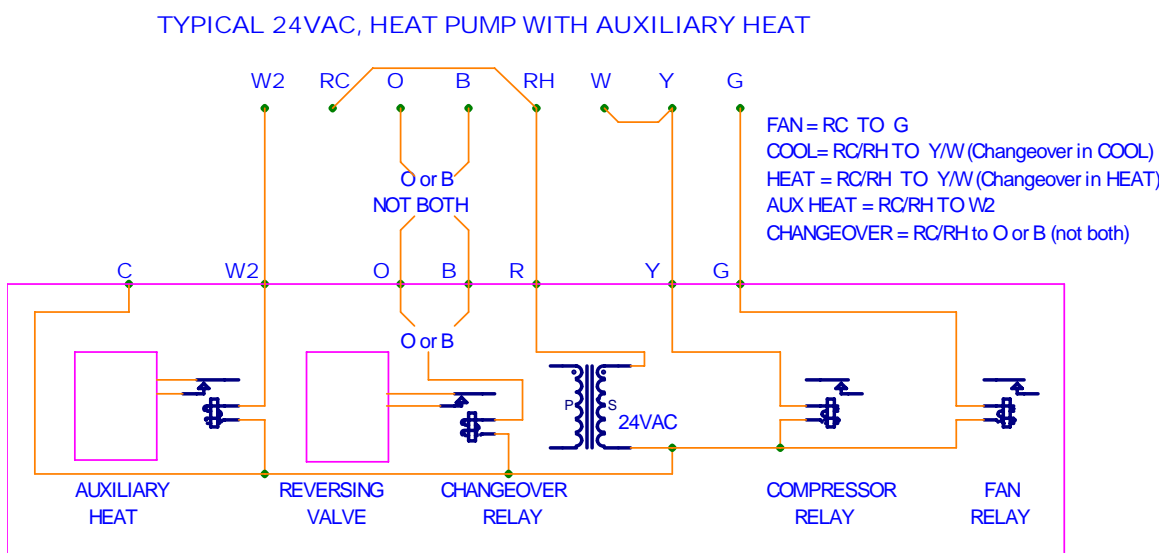

If the heat pump AUX HEAT is gas or oil it is installed at the air input side of the heat pump and cannot run when the heat pump is running or it would overheat the heat exchanger. So if the thermostat is set for GAS/OIL AUX HEAT, the thermostat will shut off the heat pump when the aux heat comes on. The heat pump is used for maintaining room temperature and the gas or oil aux heat is used for recovery.

24VAC ZONED FORCED AIR HEATING AND COOLING 6 WIRE (main)

The drawing below is a forced air, zoned, heating and cooling system with remote thermostats for different areas. The master control unit opens and closes baffles in the forced air system to open an area or close an area for either heating or cooling. This allows different areas of the house to be at different temperatures as a function of the areas own thermostat using a single HVAC system.

The selection of HEATING or COOLING is made by the master controller. If the customer wishes to use programmable thermostats at the remotes, they must remember to switch the remotes from HEAT to COOL whenever they switch the main thermostat from HEAT to COOL. This is because the heating and cooling programs are different.

Some forced air zoned systems master controllers use both B and O for changing from HEAT to COOL and some use just one of the letters, B or O. Be sure it is a gas forced air zoned system before connecting both O and B.

Some of the names of forced air zoned heating are Durazone, Trol-a-temp.

ZONE FORCED AIR HEATING AND COOLING (such as Trol-a-temp)

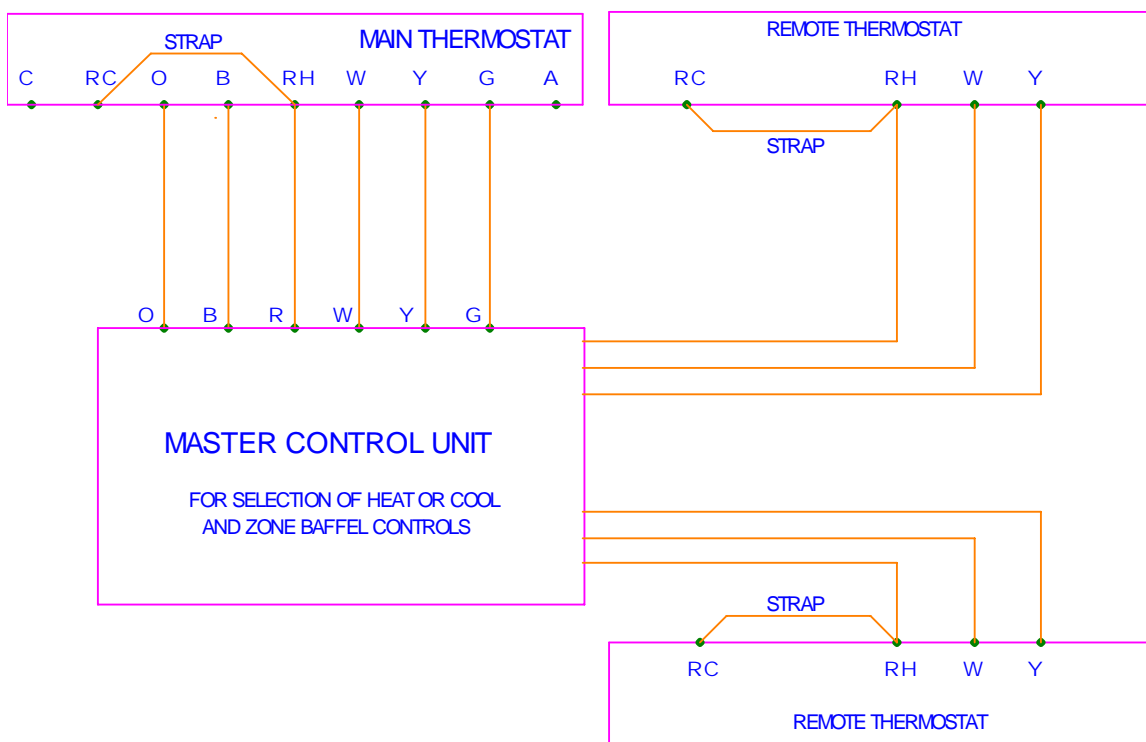

NOTE: Be sure your system is not a heat pump before connecting O and B. Connecting both O and B in a heat pump, can cause damage to the HVAC system.

ZONE HOT WATER HEATING SYSTEMS (3 wires to thermostat)

The drawing below is a zoned hot water system that uses a 3 wire thermostat control system to open and close a rotary valve or a solenoid valve.

NOTE: If a hot water system has just two wires, connect it as a standard 2 wire heating system between RH and W.

ROTARY VALVE

When the thermostat requests heat, RH connects to W and the rotary motor controlled valve opens. When the thermostat requests the heat go off, the RH to W connection opens and the RH to A connects and the rotary motor controlled valve closes. Each valve has a switch to turn the boiler on and off so the boiler can be turned on by any zones rotary switch.

SOLENOID VALVES (note reverse wiring from rotary connections)

When heat is not requested, RH is connected to A and holds the solenoid valve in the OFF position (powered off). When heat is requested, RH disconnects from A which lets the solenoid go and its spring opens the valve. At the same time, RH connects to W and turns on the boiler. Any zone's thermostat can turn on the boiler. If the valve or its power fails, the valve springs open and allows some heating by convection.

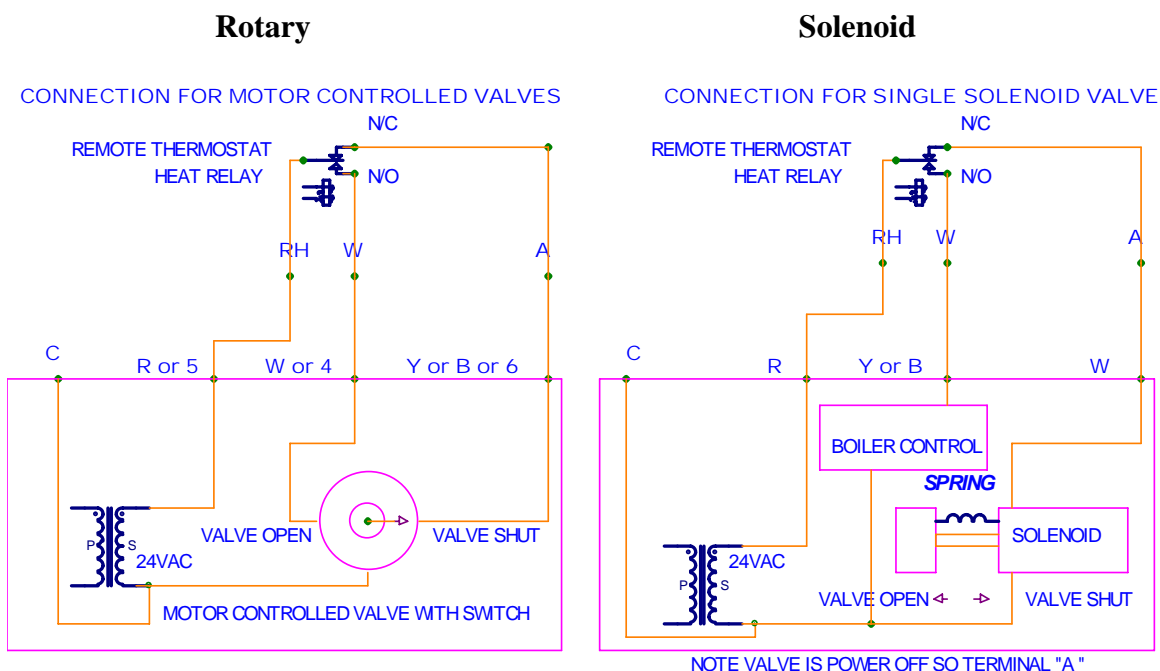

RV's, 2 speed fan's, and Swamp Coolers

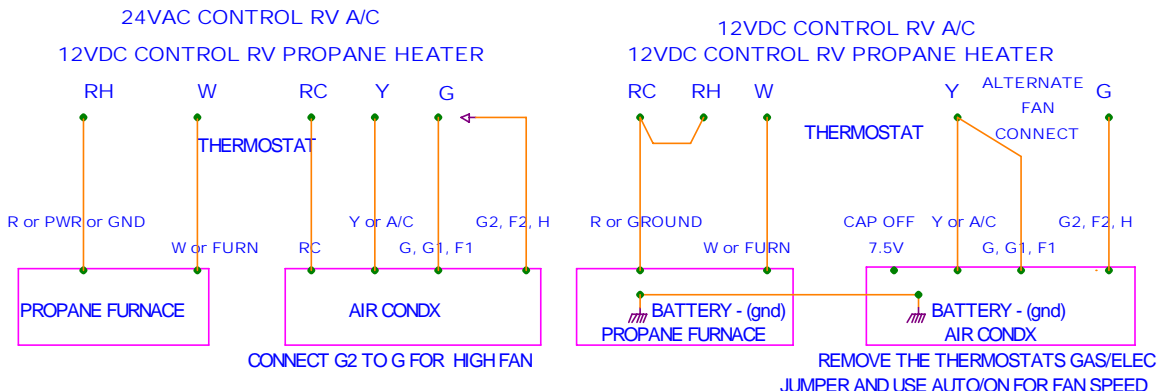

All RV air conditioners run on 115VAC and the RV must be connected to AC power for the air conditioner to operate. No Air Conditioning test can be done with out AC power.

SWAMP COOLERS

Swamp coolers connect like any A/C system (RC, Y, and G). If there is a two speed fan, connect just the G fan wire to the thermostats G terminal for low, or both fan wires (G and G2) for high. The alternate fan connection above right allows the use of the thermostats fan AUTO/ON switch to be a LOW (auto) and HIGH (on) manual switch.

Do not use a 24VAC thermostat for a line voltage swamp cooler.

MOBILE HOME

Some mobile homes have a 2 wire thermostat for heating and cooling. The HEAT/OFF/COOL switch is on the side of the HVAC system. Typically in this case, connect the two wires going to the thermostat to RH and W. Leave the thermostat always in HEAT; do not switch the thermostat to cool.

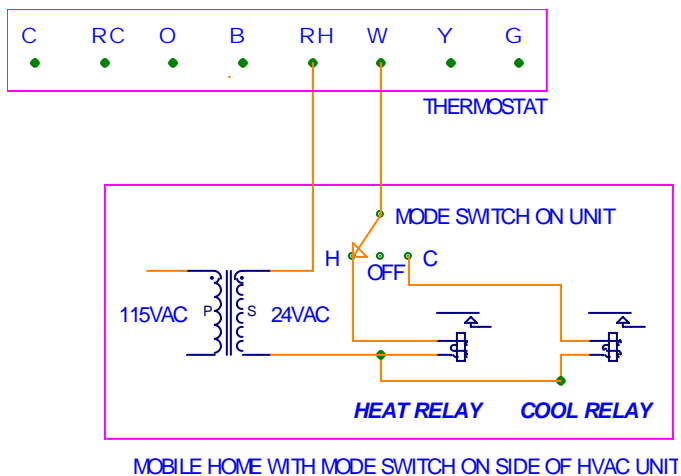

LINE VOLTAGE THERMOSTATS

NOTE: Line voltages are very dangerous and the power to the heating system should be shut off before changing the thermostat! These are typically used for baseboard, wall, ceiling and floor heating systems.

LINE VOLTAGE DOUBLE POLE (4 large wires)

The DOUBLE POLE type will have 4 large wires coming out of the thermostat. To connect to 4 large wires coming out of an electrical box in the wall. Do not connect a 24VAC thermostat to line voltage or severe damage will occur to the thermostat.

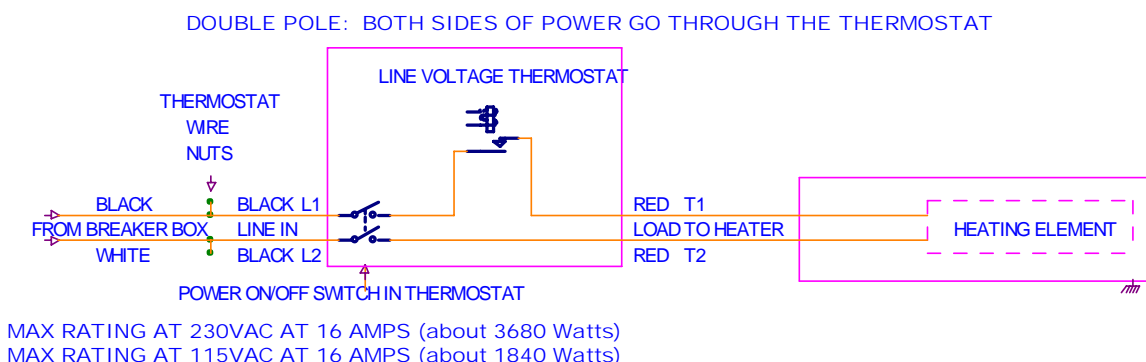

LINE VOLTAGE SINGLE POLE HEATING (2 large wires)

The SINGLE POLE type will only have two large wires coming out of the thermostat.

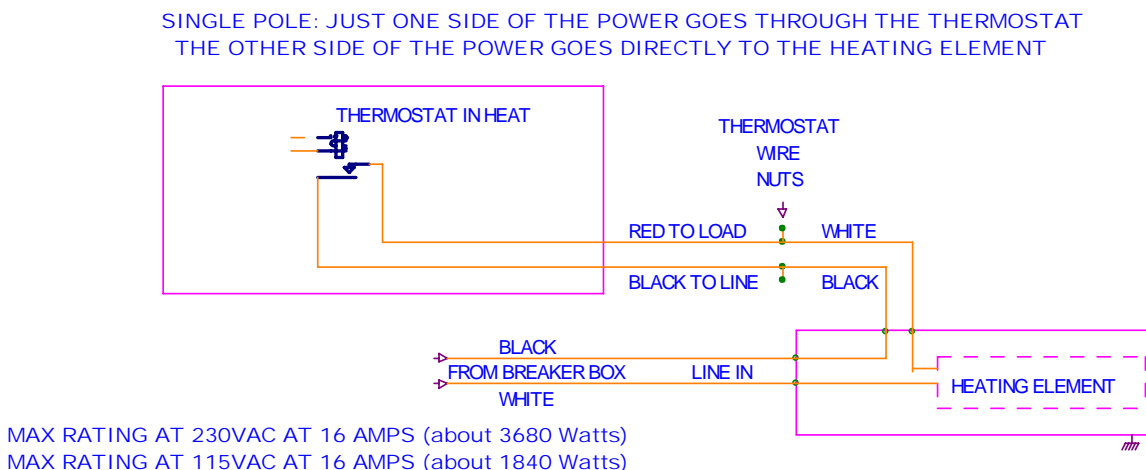

LINE VOLTAGE SINGLE POLE COOLING (2 large wires)

Some line voltage thermostats can be used for heating OR cooling as below. They will have a switch to select HEAT OR COOL (not both).

CONNECTION FOR LINE VOLTAGE COOLING THERMOSTAT (SWAMP COOLER ETC)

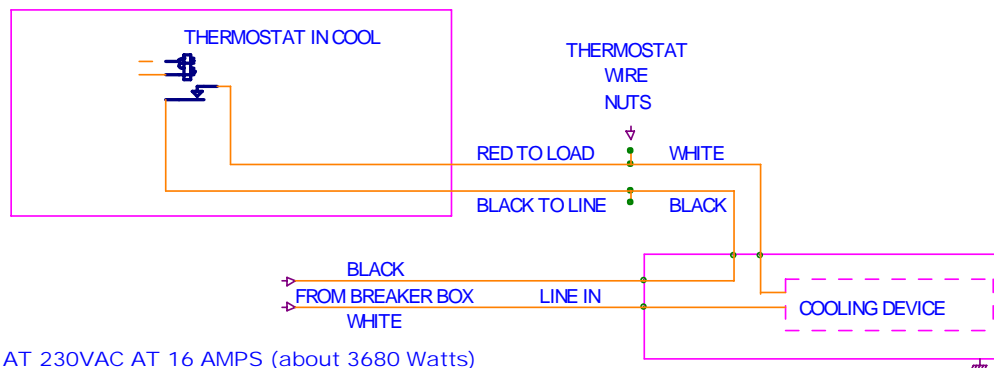

MAX RATING AT 230VAC AT 16 AMPS (about 3680 Watts)
MAX RATING AT 115VAC AT 16 AMPS (about 1840 Watts)

CONTROLLING HUMIDITY (Thermostat equipped with a built humidistat)

HUMIDIFIER

If you have a humidifier and wish your thermostat with a built in humidistat to control it, connect the humidifier as shown below. The MIN (minimum) humidity setting on the thermostat will now turn the humidifier on and off as a function of the humidity level in your home.

If the humidistat is set for ALWAYS, when humidity is requested by the humidistat, the humidifier and the fan will be turned on until the humidity is at the target (about +/- 5%).

If the humidistat is set for WITH HEAT ONLY, the humidifier will not come on until there is both a request for heat and a request for humidity at the same time. When either heat or the humidistat is satisfied and shuts off, the humidifier will shut off.

NOTE: If your thermostat has a built in humidistat (with an H terminal), and your heating system has a built in humidifier, connect it as below using the HVAC 24VAC power.

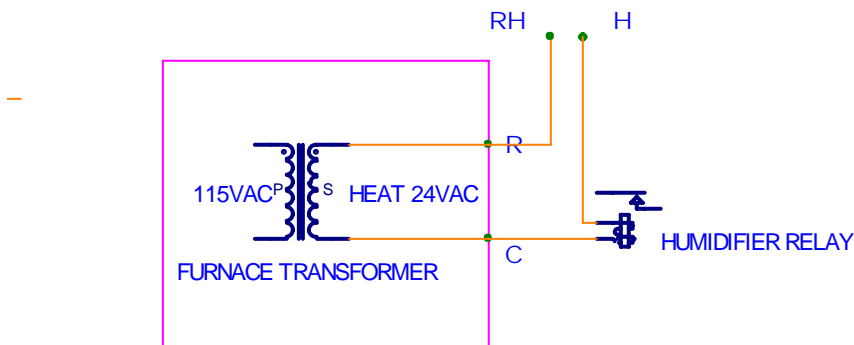

HUMIDIFIER CONNECTION USING THE HEATING SYSTEM 24VAC

NOTE: If your heating system has an added humidifier with its own separate 24VAC connect it as below.

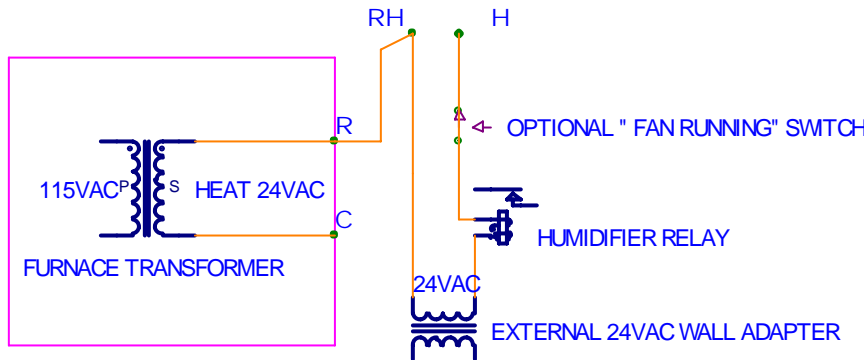

HUMIDIFIER WITH EXTERNAL 24VAC ADAPTER

CONNECTING AN EXTERNAL HUMIDISTAT FOR HUMIDIFYING

If you have an existing humidifier, with an external humidistat, and wish it to be active only when the thermostat is switched to HEAT, connect the power wire (R) from your humidistat to the B terminal of your thermostat (if it has one).

When the mode switch is put in HEAT, the B terminal is powered from the RH terminal, which will power the external humidistat. The humidistat will then operate independent of the thermostat settings. When the thermostat is switched to OFF or COOL, the external humidistat will be off.

HUMIDIFIER CONNECTION WITH AN EXISTING EXTERNAL HUMIDISTAT

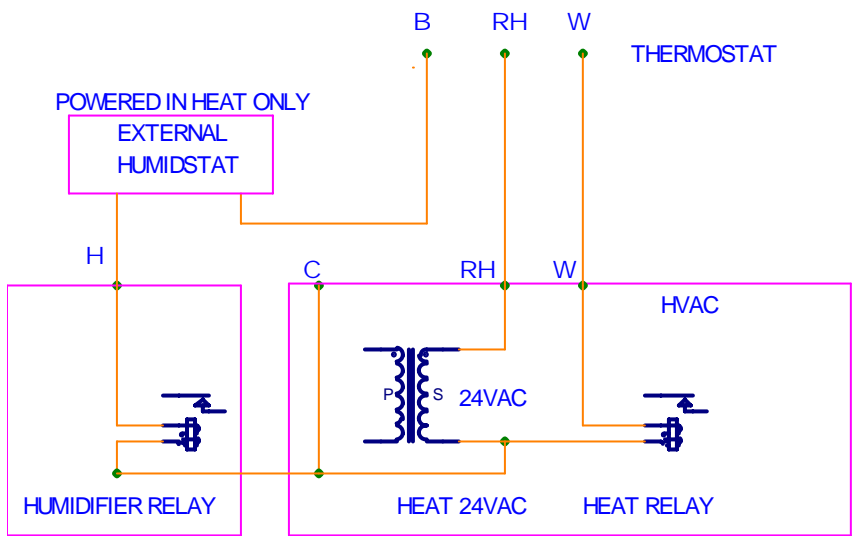

DE-HUMIDIFYING (humidistat using the air conditioner)

Some thermostats internal de-humidifier can use an air conditioner for de-humidifying or can use an external dehumidifier (DH terminal). The A/C can be used for de-humidifying or cooling, or can be set up to dehumidify only when also cooling is also required.

DE-HUMIDIFYING USING AN EXTERNAL DE-HUMIDIFIER

If a system has an external de-humidifier unit, it de-humidifies but is temperature neutral so does not add cooling to the house. If your thermostat as a humidistat that can use an external de-humidifier (DH terminal) then it can be connected as below using the cool 24VAC power source.

CONNECTION WITH AN EXTERNAL DE-HUMIDIFIER USING HVAC 24VAC POWER

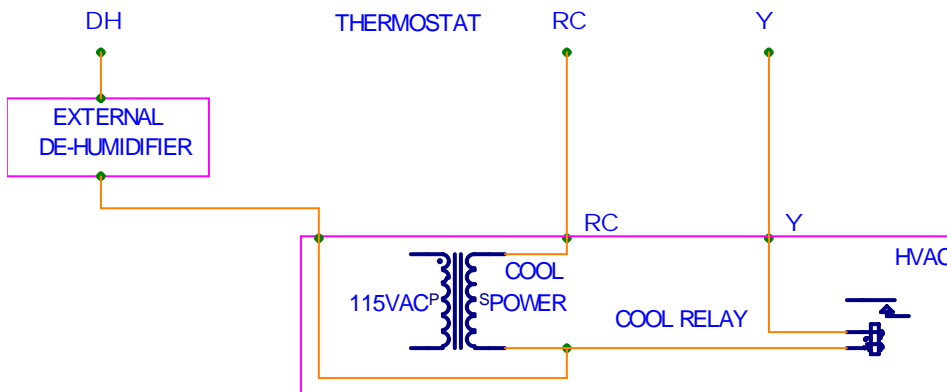

If a system has an external de-humidifier unit, it de-humidifies but is temperature neutral so does not add cooling to the house. If your thermostat as a humidistat that can use an external de-humidifier (DH terminal) then it can be connected as below using a separate 24VAC power source.

CONNECTION WITH AN EXTERNAL DE-HUMIDIFIER USING SEPERATE 24VAC POWER

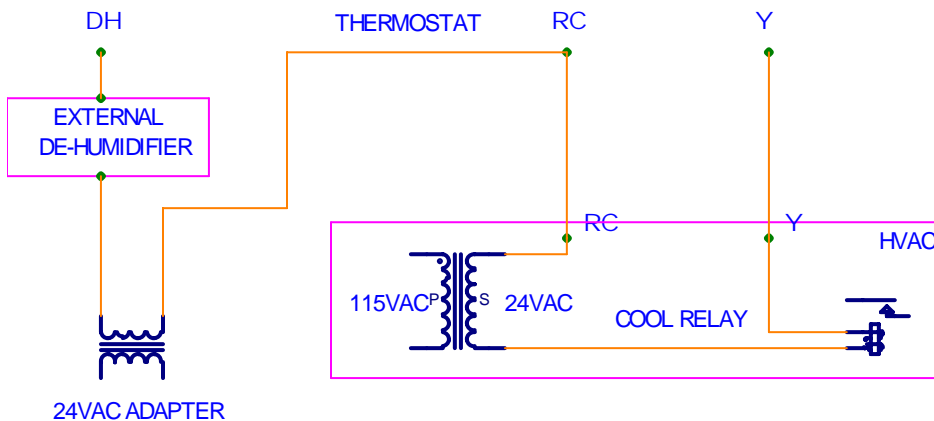

CONNECTING AN EXISTING HUMIDISTAT FOR DE-HUMIDIFYING

NOTE: The power to the external humidifier should come from the thermostats O terminal which is powered only in the cool mode so the HEAT and the A/C cannot be on at the same time.

PARALLEL: The air conditioning can be turned on by either the humidistat with high humidity over its target or by the thermostat because of high temperature over its target.

DE-HUMIDIFIER CONNECTION WITH AN EXISTING EXTERNAL HUMIDISTAT

PARALLEL: EITHER HIGH TEMPERATURE OR HUMIDITY WILL TURN ON THE AIR CONDITIONER

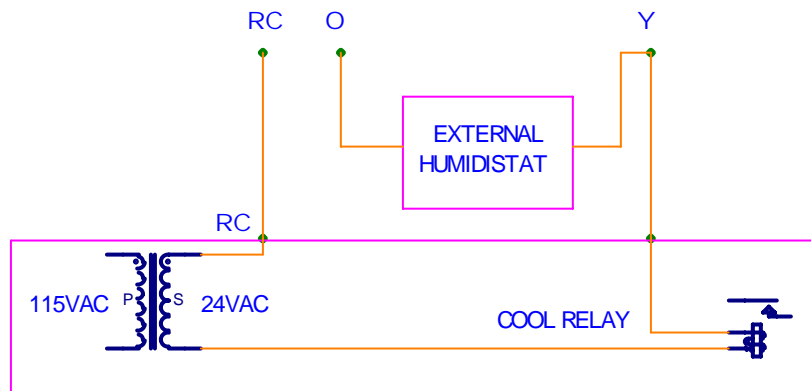

SERIES: The air conditioning will come on only with high humidity over its target and high temperature over its target.

DE-HUMIDIFIER CONNECTION WITH AN EXISTING EXTERNAL HUMIDISTAT

BOTH TEMP AND HUMIDITY MUST BE ABOVE TARGET TO TURN ON A/C

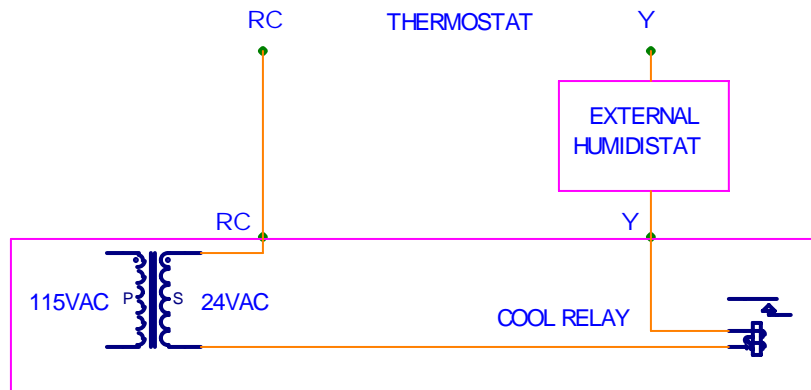

THERMOSTAT POWER

BATTERIES

Some thermostats are powered from batteries. The life of the batteries is typically between 1 and 2 years depending on how often the backlight is used.

DO NOT USE RECHARGEABLE BATTERIES (voltage too low to run)

If the batteries die, the thermostat will quit operating with the HVAC off. The LOW BATTERY icon will come on for several weeks before this happens. When changing batteries do it quickly (30 seconds) or you may lose your time and custom program settings. The thermostat will still function and default to the built in Energy Star program, but would still need to have the day and time re-set. All manual functions will continue to work.

24VAC POWER

Some thermostats can also use the 24VAC heat power if available. One side of the 24VAC is the power wire at the thermostat going to the RH terminals. The other side of the 24VAC is called the "C" wire and if available at the thermostat, can be connected to the thermostat's C terminal. This will allow the thermostat to get its power from the furnace so the battery life will about double. Thermostats with a backlight will have the backlight also be powered from the 24VAC power. If you have a wire you think is the C wire, a test is to measure the AC voltage as follows:

1. Connect the RH and W terminals with a piece of wire or a paper clip. Doing this turns on the heat.
2. Between the proposed C wire and the RH wire terminal should be about 24VAC to 28VAC with the heat on.

The batteries are still necessary to retain the thermostat's custom programs and other settings if the AC power to the furnace is interrupted. Using the 24VAC (C wire), the thermostat will continue to run if the batteries die. The C wire is shown in all of the heat connection drawings. If there is an unused wire in the wall, an HVAC tech can connect it for you or run another wire.

THERMOSTATS WITH RADIOS AND/OR REMOTE CONTROL (require C wire)

Thermostats with remote control must have the 24VAC for the remote's receiver inside the thermostat to work. The remote receiver in the thermostat requires power and would substantially reduce battery life so cannot run on the batteries.

If the C wire is not readily available, a 24VAC plug-in power adapter may be used by connecting its wires to the thermostat's terminals RH and C. There is no polarity of the two wires so either wire can go to either terminal. The Radio Shack Cat No. 273-1690 adapter can be used. Cut off its connector and connect the two wires to RH and C; put its switch on 24VAC.

FAN CONTROL

MANUAL (auto/on)

The normal position for the fan switch is AUTO which allows the fan to be controlled by the furnace or by the thermostat as explained below. In the ON position, the fan will run continuously. This can keep your house at a more even temperature and if you have a good clean air filter system can reduce dust and smells.

HEATING (gas/electric selection)

Most forced air heating systems that use gas or oil has their own fan control. When the heating system is hot enough its “stack” upper limit temperature switch turns on the fan. When the house is up to temperature, the thermostat shuts off the burner, the stack cools down, and the furnace’s lower limit temperature switch shuts off the fan. These limits switches control the fan when the thermostats gas/elect jumper selector is in GAS. Electric heating systems can also have fan control as above but most do not and rely on the thermostat to turn the fan on and off with the electric heat. Electric heat should not be turned on without air circulating over the heater elements. For electric furnaces and heat pumps, the thermostats fan control jumper selector (gas/elect) should be set in the ELECT position. When the thermostat is controlling the fan, it may have additional capabilities such as leaving the fan run 1 min after the heat goes off (purging) or the option of having the fan run a minimum of 5 minutes per hour for better air circulation.

COOLING

Air conditioners (AC) do not have internal fan control and require the thermostat to turn the fan on and off with the compressor. Your thermostat does this as long as the GAS/ELECT jumper is in either GAS or ELECT. Some AC systems control the fan separate from the thermostat. These newer units turn the fan on with the compressor, and then leave the fan running for a while after the compressor has shut off. This is more efficient by clearing out the residual cool air after the compressor has shut off. When the thermostat is controlling the fan, it may have additional capabilities such as leaving the fan run 1 min after the cool goes off (purging) or the option of having the fan run a minimum of 5 minutes per hour for better air circulation.

GENERAL INFORMATION

SWING

Swing is the temperature difference between where a system comes on and then goes off. Most programmable thermostats have the ability to set the swing.

EXAMPLE: The thermostat is set at HEAT, a target temperature set at 70F, and the swing is set at 1F. The heat would typically come on at 71 and go off at 69. The lower number gives a higher comfort level as the room temperature is more constant and the HVAC system will cycle more often. The higher number is more efficient and the HVAC system will cycle less often.

ANTICIPATORS

Mechanical thermostats use anticipators. This is a resistive device that heats up when the thermostat has turned on the heat. The anticipator gets warm; heating the thermostat so that it will shut off the heating system earlier than it would have without the anticipator. This is done because there is a delay in the reaction of the thermostat's temperature sensor spring due to the thermal mass of the mechanism. The typical swing in a mechanical thermostat can be wide and get wider with age. Anticipators are not necessary in electronic thermostats because the mass of the temperature sensor is very small.

ELECTRONIC THERMOSTATS ACCURACY

Most thermostats are specified and checked at +/- 1F. The room temperature measured by the thermostat is a function of the room, wall, and radiant temperatures near the thermostat. For better accuracy, fill the hole in the wall with insulation so the thermostat's room temperature will not be affected by air flow in the wall. When you are installing a thermostat, the room temperature will initially read high because the case has been warmed by your hands. It may take several hours for the thermostat to stabilize to room temperature. If your new thermostat does not match your old thermostat, the error is probably a combination of the two thermostats' accuracy. Some thermostats allow you to change or "calibrate" the room temperature to match another device, or to set it for a comfort level in a different room.

CALIBRATION (if the thermostat has room temp set)

If you wish to have the room temperature reading on your thermostat match some other device, use the units calibration function.

The (delta sign) T-FACTOR means the change in room temperature setting when you "calibrate" the room temperature to your liking. When you change the room temperature with the "calibration" function, the display shows you both the new room temperature and the T-FACTOR which is how much you changed the room temperature display.

COMPRESSOR DELAY

Most electronic thermostats with cool or heat pump capability have a build in approx 4 minute delay from the time a compressor turns off until the thermostat can turn it back on. This is allows the unit to de-compress which prevents compressor stall.

1. If a customer has his compressor running (heat or cool) and changes his target to shut it off, then within 4 min decides to turn it back on, it will not come on until the end of the delay.
2. The delay can be terminated by switching to OFF and back on. Do not do this if the compressor has been running; wait 4 minutes before turning it back on.
3. Always reset with mode switch in OFF.
4. If connected to a C wire, the delay occurs if AC power is lost and then restored.
5. There is no delay in NORMAL HEAT.

DIFFERENTIAL (2 or more stages of heat and/or cool)

When the room temperature is below the target temperature by more than the differential, the next stage will come on with the 1st stage all the way to room temperature. Then the 1st stage will attempt to maintain the room temperature by itself. If the room temperature goes below the differential again the next stage will come on. A typical differential may be over -2F for heat and over +2F for cool.

RESET

The thermostats reset button should be pushed after initially putting in the batteries. It should also be pushed if any set up is changed using the little jumper. Reset restores factory settings including the program which goes back to the EPA Energy Star.

TROUBLE SHOOTING

The thermostat simply connects the wires coming to the thermostat together as needed to control a given function. The thermostat uses an isolated relay that makes these connections. The thermostat does not have, or generate any power, it simply switches the power (RC and RH) coming to the thermostat to the appropriate control wires for heat (W), compressor (Y), fan (G) etc.

FAN CHECK

RC is used as power for the fan and G is the fan return wire. Connecting RC to G should turn the fan on. If it does not the problem is in the fan system. This may indicate the low of the 24VAC power.

HEAT CHECK

RH is power for the heat and W is the heat return wire. Connecting RH to W with a wire or paper clip (used as a wire) should turn the heat on in either 24VAC or GAS millivolt systems. If the heat does not come on, the problem is in the heating system.

COMPRESSOR CHECK

RC is used as power for the cooling compressor and Y is the compressors return wire. Connecting RC to Y should turn on the cooling compressor (outside unit).

WARNING: When checking the compressor, DO NOT shut if off and right back on. After it has been on and then off, wait for 4 minutes before turning it on again to prevent compressor stall.

24VAC POWER CHECK

In a 24VAC system, if nothing works, the 24VAC power may be off. This can be because of lack of main power to the heating system (check breakers), or a blown fuse on the 24VAC line. To check for the 24VAC power, use an AC voltmeter and measure between the RH and the W terminals with the heat off; there should be 24 to 28VAC.

TESTING FOR SHORT CYCLING (heat cycling on and off)

If you're heating system sounds like it is cycling on and off too often, try increasing your SWING setting on your thermostat. Another check is to connect the RH terminal to the W terminal with a wire. This will turn on and hold on your heat as long as RH is connected to W. If the furnace still short cycles the problem is in the furnace. The problem could be your heating system's stack switch settings that control the fan or a clogged air filter.

TESTING FOR LONG CYCLING (Furnace or AC runs almost continuously)

If your HVAC system is running continuously and the room temperature is not changing, the problem may be the HVAC system cannot keep up with the heating or cooling settings because of outside temperature extremes. If the room temperature never gets to or crosses the target temperature setting the thermostat is not going to shut the HVAC off. Again, check your air handler filters.

HEAT: Lower your target temperature 5F below your room temperature, the furnace should shut off in a few minutes which indicates the thermostat is working.

COOL: Raise your target temperature 5F above your room temperature, the cool should shut off in a few minutes which indicate the thermostat is working.

FAN NOT RUNNING IN COOL

In cool if the fan comes when the thermostat fan switch is moved to ON, but the fan does not come on when the compressor starts, check to see if the GAS/ELEC selection is on gas or elect. It must be in gas or elect for the thermostat to control the fan in cool.

THERMOSTAT RANDOMLY RESETS

If your electronic thermostat randomly resets back to its original settings and time, it may be caused by radio frequency interference (RFI) or RF noise. This is more prevalent in gas furnaces with spark igniters that are close to a digital thermostat. If this occurs, the RFI can be reduced and/or eliminated by adding an RF chock on the leads going from the furnace to the thermostat. This is very easy to do.

The Radio Shack ferrite data line filter cat # 273-105 is a clip on device the goes around all the wires going to the thermostat. It is best to put it at the furnace end if easy to get to, but may also be used on the wires at the thermostat end. In some cases, one at each end is even better. If the wires are too large for that filter, the Radio Shack snap on RF chock cat #273-104 may be used.

TRANE HEAT PUMP B WIRE

Some systems built by Trane do not use the NEMA standard for the "C" (power common) wire. They use a wire labeled "B" for the common power wire. If both the O wire and the B wire are present on a Trane product heat pump, connect the O to O but do not connect the B wire to the B terminal or damage to the 24VAC power will occur.

SAFETY

LINE VOLTAGE THERMOSTATS

Always shut off the power at the breaker box before wiring any thermostat. If you have line voltage heating or cooling, be sure to use a line voltage thermostat. Connecting a line voltage thermostat to a low voltage 24VAC thermostat is dangerous and will damage the thermostat. All line voltage thermostats have large wires coming out of the thermostat and connect to large wires in an AC box with large wire nuts.

24VAC

If the power wire (R, or RH or RC) touch the power common wire (C or X) damage to the 24VAC power will occur. Never connect the C wire to any other wire.

If you have separate heat (RH) and cool (RC) power wires do not let these wires touch each other. Also, if you have both RC and RH wires, be sure to remove the jumper wire between RC and RH before connecting any wires.

If you have a heat pump with both O and B wires, it is probably a Trane product and the O should be connected to O but the B should not be used until you are sure it is the power common wire. Then it can be connected to the thermostats C terminal.